

Recuperated High-Velocity Burner NOXMAT® K-RHGB

- indirect heating -

Main dimensions / Connection sizes

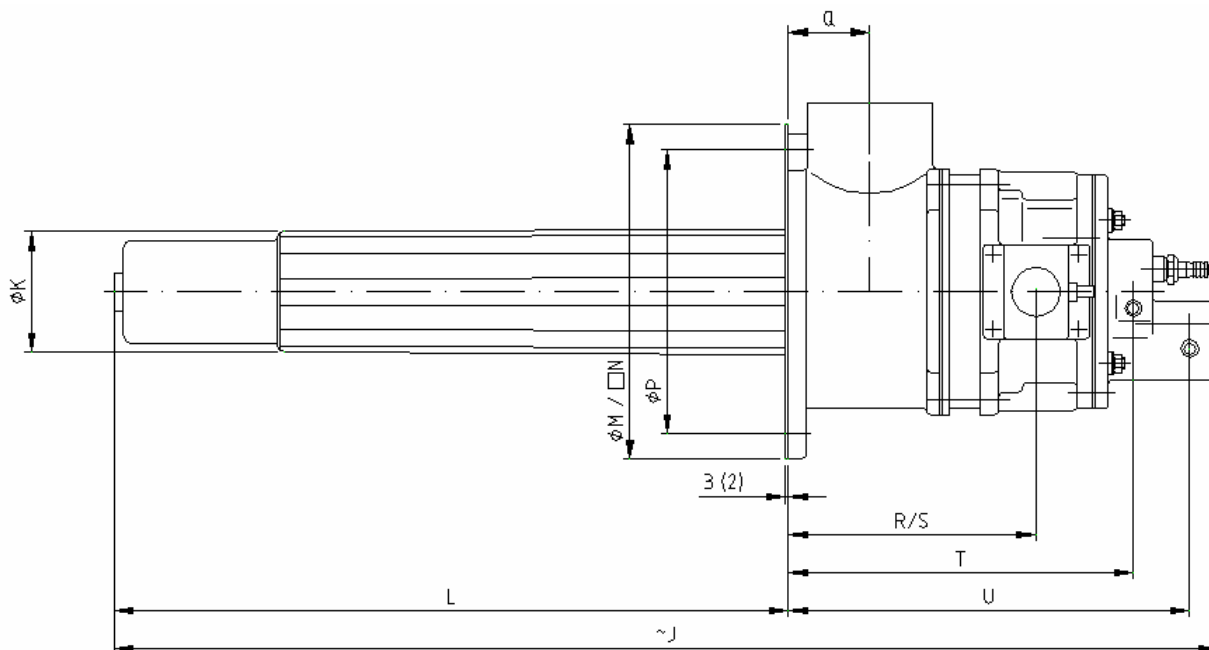
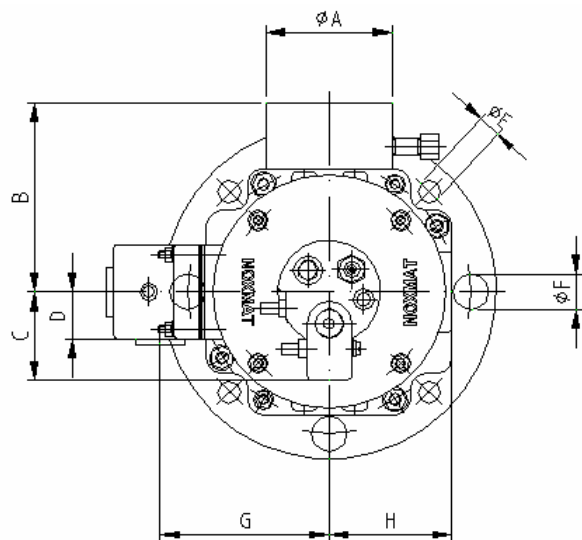

Burner size	Main dimensions														Connection sizes									
	A	B	C	D	E	F	G	H	J	K	L ^[1]	M	N	P	Waste gas		Combustion air		Cooling air		Purge air		Fuel gas	
	mm	mm	mm	mm	mm	mm	mm	mm	mm	mm	mm	mm	mm	mm	mm	mm	mm	Zoll	mm	Zoll	mm	Zoll	mm	Zoll
K-RHGB 15-G	90	130	80	30	18	----	125	85	910	63	535	----	180	210	60	Ø35	185	G3/4	185	G3/4	259	G3/8	304	Rp1/2
K-RHGB 15	90	130	80	30	18	----	125	85	910	85	535	----	180	210	60	Ø35	185	G3/4	185	G3/4	259	G3/8	304	Rp1/2
K-RHGB 25	100	150	70	37	18	28	134,5	97,5	880	100	535	265	----	225	65	Ø50	197	G1	197	G1.1/2	274	G3/8	319	Rp1/2
K-RHGB 40	100	180	77	30	18	28	158	105	890	125	535	320	----	280	65	Ø55	205	G1.1/2	205	G1.1/2	283	G3/8	328	Rp1/2
K-RHGB 80	100	190	50	48	18	28	180	122,5	880	150	535	340	----	300	65	Ø65	200	G1.1/2	200	G1.1/2	277	G3/8	319	Rp1/2
K-RHGB 160	128	245	70	41	24	34	234	175	960	208	535	440	----	395	85	Ø82	240	G2	240	G2	332	G3/8	390	Rp3/4

^[1] Variable length