

TYPE TC/TCG MESH BELT CONVEYOR

Technical data – standard range

Type	Useful dimensions		Throughput *
TC /TCG	Belt width	Heated length	
80/36	600 mm	3600 mm	390 kg/h
80/54	600 mm	5400 mm	580 kg/h
80/72	600 mm	7200 mm	780 kg/h
120/54	900 mm	5400 mm	875 kg/h
120/80	900 mm	8000 mm	1300 kg/h
160/54	1200 mm	5400 mm	1170 kg/h
160/80	1200 mm	8000 mm	1730 kg/h

TC : Electrical heating  
TCG : Gas heating

\* Guideline values for carbonitriding, case depth 0,1 mm

Ancillary equipment for integration into automatic heat treatment lines

Type TC/TCG furnaces can be linked up to other equipments to form an automated process.

Every production line is designed individually, to suit each user's specific requirements and the available floor space.

All the SAFED units listed below are compatible with each other and meet exacting standards of reliability:

- Automatic loading systems matched to the parts being processed and the preceding production stages.
- Continuous degreasing plants available as drum and conveyor version for aqueous cleaning of parts before and after hardening.
- Mesh belt conveyor tempering furnaces, with air circulation or protective gas atmosphere, precisely matched to the output of the hardening furnace.



Automatic heat treatment line



**Four Electrique Delémont S.A.**  
36, rue Emile-Boéchat  
CH-2800 DELEMONT  
Tél. + 41 (0)32 4 21 44 60  
Fax + 41 (0)32 4 21 44 64

[contact@safed.ch](mailto:contact@safed.ch)

[www.safed.ch](http://www.safed.ch)

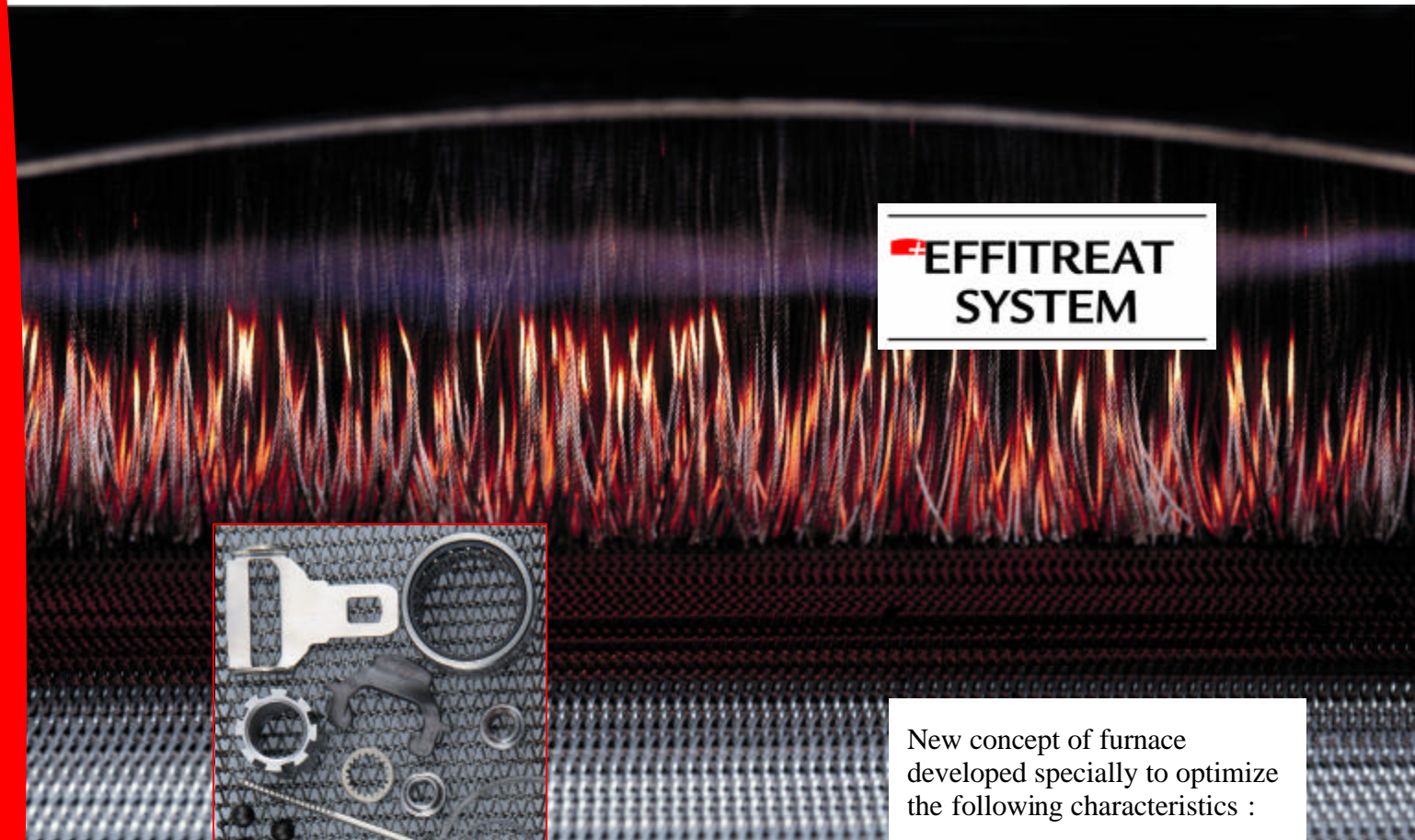

New concept of furnace developed specially to optimize the following characteristics :

- productivity
- energy saving
- reproducibility of heat treatments
- reduction of maintenance costs
- lowering of production overheads

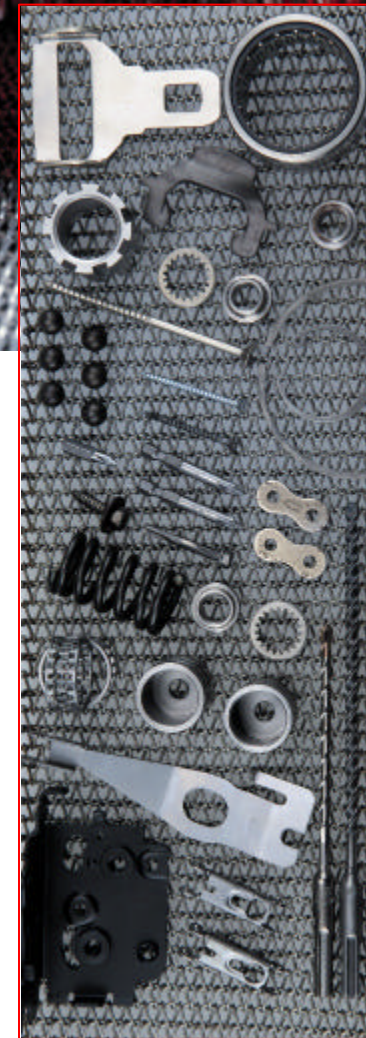



### Concept

EFFITREAT System is designed and produced by SAFED, for continuous heat treatment of mass-produced and limited run parts, and can be integrated easily into the total manufacturing process.

It fulfils the very strict requirements of quality assurance and profitability.

The concept of the oil quench was also improved and can be used by both types of furnace.

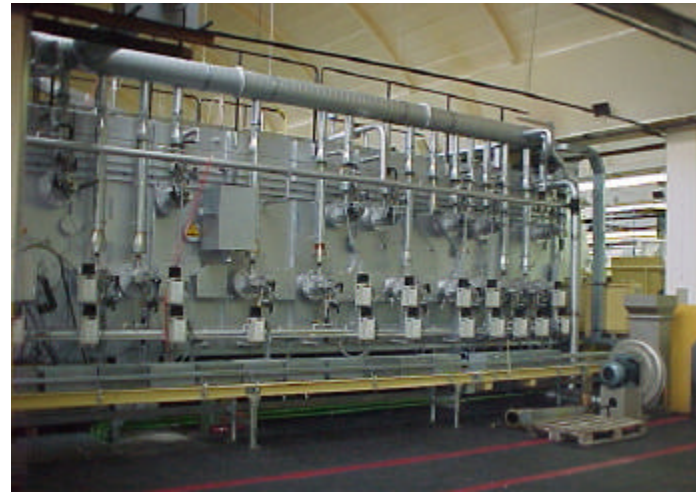

- Gas-tight casing
- Continuous drive of the mesh belt conveyor by synchronized drum drive motors
- Forced gas convection by powerful turbines
- Electric or gas heating by ceramic radiant tubes
- Insulating material and optimization of the furnace casing assembly have improved the energy balance of the furnace.
- Easy access inside the furnace by a rear door.
- PLC control

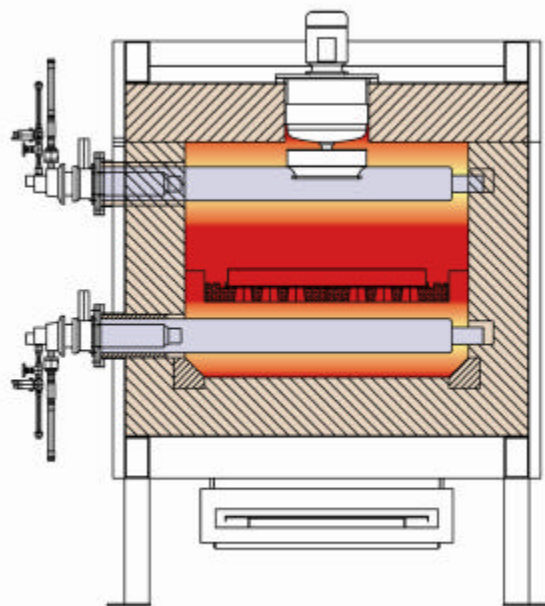

Furnace's heating by electricity or gas. All heating elements can be replaced without dismantling the furnace.

The high precision and reproducible standards of this process mean that the required metallurgical and mechanical properties can be achieved on a wide range of parts.

The equipment is ideal for the following applications:

- Mass-produced parts for the automotive industry
- Screws and other fasteners
- Antifriction bearing components
- Fine-blanked parts and deep-drawn components
- Components for roller chains
- Tools such as saw blades, drills and screwdrivers
- All kinds of small components



Type TC 160 furnace, gas-heated, capacity up to 1800 kg/h